



LHR Series-High Rate

LHR12350W(12V350W)



Specyfikacja

Napięcie znamionowe	12V	
Moc znamionowa (W ,1.67V/cell)	350W	
Pojemność znamionowa(C ,1.80V/cell)	85Ah	
Wymiary	Długość	293±2mm (11.53 inches)
	Szerokość	173±2mm (6.81 inches)
	Wysokość	213±2mm (8.39 inches)
	Całkowita wysokość	216±2mm (8.50 inches)
Waga	26.8 Kg (59.08 lbs)	
Terminal	M8	
Typ obudowy	ABS(UL94 V-0)	
Pojemność (25°C)	85.0 Ah	(10hr, 8.50A, 1.80V/cell)
	80.8 Ah	(8hr, 10.1A, 1.80V/cell)
	71.0 Ah	(5hr, 14.2A, 1.75V/cell)
	60.6 Ah	(3hr, 20.2A, 1.75V/cell)
	53.2 Ah	(1hr, 53.2A, 1.67V/cell)
Maksymalny prąd rozładowania	1350A	
Rezystancja wew. (25°C)	Okolo. 5.0mΩ	
Temperatura pracy	Rozładowanie	-20 ~ 55°C (4 ~ 131°F)
	Ładowanie	0 ~ 40°C (32 ~ 104°F)
	Składowanie	-15 ~ 50°C (5 ~ 122°F)
Nominalny zakres pracy (temp.)	25±3°C (77±5°F)	
Max.Prąd ładowania(25°C)	21.25A	
Napięcie ładowania(25°C)	Float	13.5V
	Temp. Coefficient	-3mV/cell/°C
	Equalization	14.1~14.4V
Kompensacja temperaturowa	40°C (104°F)	106%
	25°C (77°F)	100%
	0°C (32°F)	86%
Samorozładowanie	≤3%/mies. @ 25°C	



Wymiary

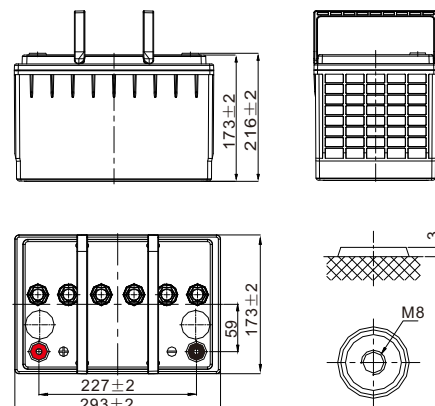

Stałoprądowa charakterystyka rozładowania(Ampery) at 25 °C (77°F)

F.V/Czas	5min	10min	15min	20min	30min	45min	1h	1.5h	2h	3h	4h	5h	8h	10h
1.85V/cell	258.3	178.4	140.5	100.9	73.7	52.9	41.7	29.5	24.5	18.2	15.2	13.3	9.88	8.34
1.80V/cell	291.4	208.3	165.3	110.2	79.3	57.2	45.1	31.8	26.1	19.4	16.0	13.8	10.1	8.50
1.75V/cell	306.4	221.5	176.7	119.3	85.2	60.7	47.8	33.7	27.4	20.2	16.3	14.2	10.3	8.58
1.70V/cell	315.2	230.4	188.0	133.2	93.8	65.6	50.9	35.8	28.3	20.7	16.8	14.4	10.5	8.67
1.67V/cell	326.4	238.6	190.9	144.3	100.2	69.0	53.2	37.4	29.1	21.2	17.2	14.7	10.6	8.75
1.60V/cell	346.8	243.8	193.8	151.2	101.0	70.0	53.9	37.9	29.8	21.6	17.6	15.0	10.8	8.84

Stalomocowa charakterystyka rozładowania (Watts/cell) at 25 °C (77°F)

F.V/Czas	5min	10min	15min	20min	30min	45min	1h	1.5h	2h	3h	4h	5h	8h	10h
1.85V/cell	443.3	368.0	292.7	196.5	149.4	112.5	90.9	67.2	55.3	42.2	34.7	29.5	20.9	17.6
1.80V/cell	501.0	410.1	326.2	222.9	165.0	122.1	97.7	72.4	59.7	45.2	36.7	31.2	21.8	18.4
1.75V/cell	540.0	428.0	340.5	241.0	175.9	128.8	102.8	75.6	62.0	46.6	37.9	32.2	22.3	18.6
1.70V/cell	573.9	433.3	344.7	259.2	185.1	134.7	107.4	78.2	63.6	47.9	38.9	32.8	22.5	18.7
1.67V/cell	595.0	440.0	350.0	276.1	195.7	140.8	112.1	81.0	65.4	49.3	39.9	33.4	22.8	18.9
1.60V/cell	603.5	449.5	362.0	286.2	202.5	146.5	116.6	83.5	66.8	50.3	40.4	33.8	23.0	19.0



LHR Series-High Rate

LHR12350W(12V350W)



Aplikacje

- UPS
- Szpitale i laboratoria
- Oświetlenie awaryjne
- Urządzenia do sterowania procesami
- BAnki i instytucje finansowe
- Data & Network Operation Centers

Główne cechy

- Obudowa ABS: UL94 V-0
- Sprawność rekombinacji tlenu: $\geq 98\%$
- Wysokiej jakości separator AGM wydłużający żywotność i zapobiegający zwarciom cel
- Unikalny projekt zaworów: redukuje utratę wody i zapobiega dostawianiu się powietrza do środka
- PbCaSn zmniejsza gazowanie, ogranicza samorozładowanie

Standardy

- Zgodne ze standardem IEC 60896
- Klasyfikacja "Long Life" według Eurobat
- Certyfikat CE, UL
- Wyprodukowano w Leoch@ zgodnie z certyfikatami IATF16949, OHSAS 18001, ISO 9001 and ISO 14001

Charakterystyka rozładowania

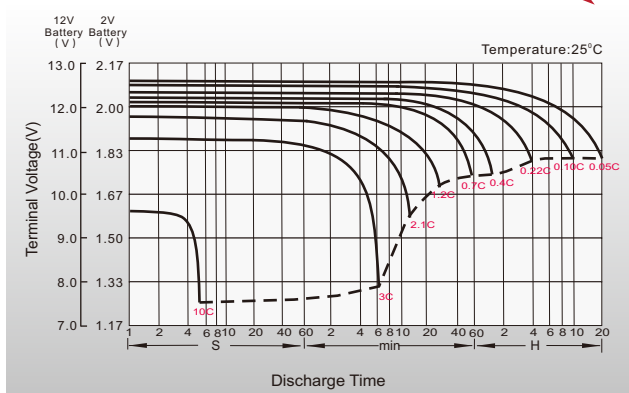

Charakterystyka doładowywania

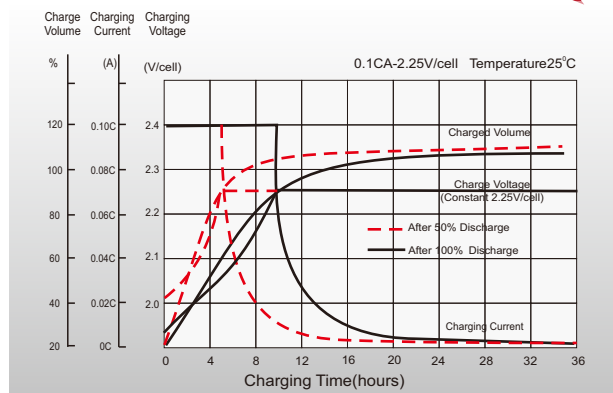

Wpływ temperatury na czas rozładowania

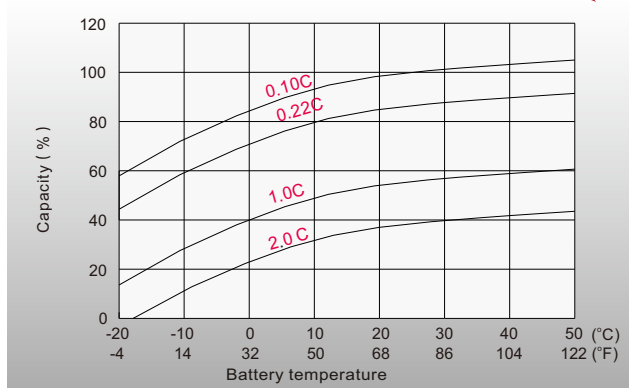

Charakterystyka samorozładowania

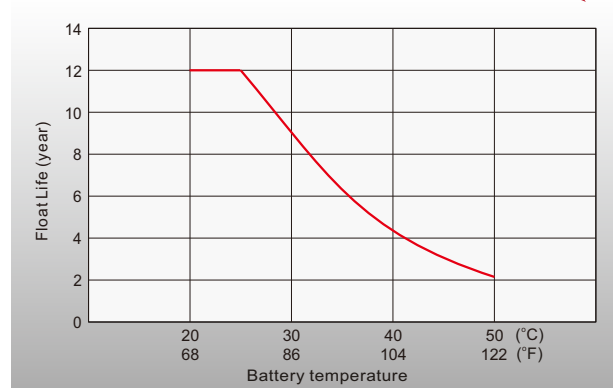

Biura sprzedaży

Polska

AG IT Project Sp. z o.o.
Pasmugi 4, 21-345 Borki
Tel: +48 601 869 159
www.agitproject.pl
E-mail: kontakt@agitproject.pl

North America Sales Office

19751 Descartes
Foothill Ranch, CA 92610, USA
Tel: 949-588-5853
Fax: 949-588-5966
E-mail: sales@leoch.us
Http:// www.leoch.us

HongKong Sales Office

Workshop C, 33/F, TML Tower, No. 3 Hoi Shing Road,
Tsuen Wan, New Territories, Hong Kong
Tel: +852 35786666
Fax: +44 1452 690125
E-mail: sales.hk@leoch.com

UK Sales Office

9B Wheatstone Court, Waterwells, Business Park,
Gloucester, GL2-2AQ, UK United Kingdom
Tel: +44(0) 1452 729428 / 1452 729696
Fax: +44 1452 690125
E-mail: Sales.Europe@leoch.com
Http:// www.leoch.eu

Singapore Sales Office

No. 1 Tech Park Crescent,
Singapore 638131
Tel: +65 68636078
Fax: +65 6863 6079
Email: sales.sg@leoch.com

EMEA Sales Office

1 Deligiorgi St., 121 31 Athens,
Greece
Tel: +30 210 5760318 (2 lines)
E-mail: support_EMEA@leoch.com
Http:// www.leoch.eu

Australia Sales Office

2 /29 Tarlington Place, Smithfield, NSW 2164
Australia
Tel: 02 9756 0950
E-mail: sales.au@leoch.com

India Sales Office

Shed no. A-53(b), 2nd Stage of Peenya Industrial Area,
Bangalore North Taluk, Bangalore-560058, India
Tel: +91-80-23440018/23440019
Fax: +91-80-23440017
E-mail: indiasales@leoch.com



[Http://www.leoch.com](http://www.leoch.com)

© 2019 LEOCH. All rights reserved.

Trademarks and logos are the property of LEOCH and its affiliates unless otherwise noted.
Subject to revisions without prior notice.

Publication No.: LB-LHR12350W 202301 PL